



Compact 4-in-1 Air Quality Sensor Module

(Model: ZH10-VHT)

Manual

Version: 1.0

Valid from: 2023-03-12

Zhengzhou Winsen Electronic Technology Co., Ltd

ZH10-VHT Compact 4-in-1 Air Quality Sensor Module

Description:

ZH10 Compact 4-in-1 Air Quality Sensor Module is a common type, miniature size sensor module, using laser scattering principle to detect the dust particles in air, with good consistency and stability. Internal integration of MEMS, VOC, temperature and humidity sensors, processed by professional algorithms and calibrated detection processes. The sensor has good consistency and stability. The sensor has both serial output and PWM output capabilities, which is easy to use, small in size, and easy to integrate.

Features:

Good consistency;
Real time response;
Accurate data;
Miniature size;
Good anti-interference ability;
Minus resolution of particle diameter 0.3 μm ;
Compatible with VOC and temperature and humidity output.

Main Applications

Air purifiers;
Ventilation systems;
Portable instrument;
Air quality monitoring equipment;
Air conditioner;
Consumer electronics products.

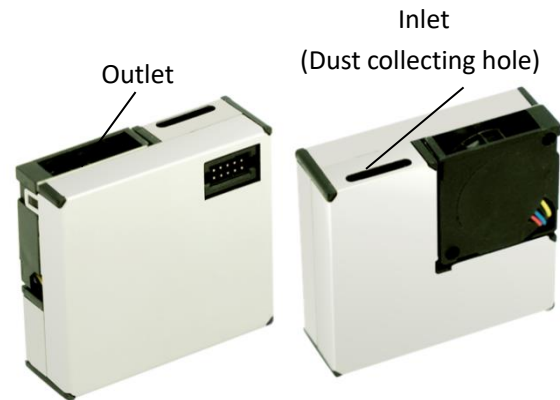

Table1-Specifications

PM2.5	Detectable Particle Diameter	0.3-10 μm
	Effective Range	0-1000 $\mu\text{g}/\text{m}^3$
	Detection Interval	1s
	Detection Accuracy	0-100 $\mu\text{g}/\text{m}^3$: $\pm 10\mu\text{g}/\text{m}^3$; 101-1000 $\mu\text{g}/\text{m}^3$: $\pm 10\%$ reading (Test condition: $25\pm 2^\circ\text{C}$, $50\pm 10\%\text{RH}$, TSI8530, smoke, GBT18801-2015)
VOC	Preheating Time	<10s
	Detection Accuracy	$\pm 20\%$ (@0.5-1ppm); $\pm 25\%$ (@5ppm)
Data output	Preheating Time	<5min
	Temperature	$-10\sim 60^\circ\text{C}$; $\pm 1^\circ\text{C}$; Resolution: 0.1°C
Humidity	15~90% RH(No Condensation); $\pm 5\%$ RH; Resolution: 1%RH	
Working Voltage	UART_TTL Output(3.3V Level, Default) PWM Output(3.3V Level, Default)	
Working Current	5V $\pm 0.5\text{V}$ (DC), Ripple $\leq 50\text{mV}$	
Dormancy Current	<150mA	
Working Humidity	<40mA	
Working Temperature	15~90% RH(No Condensation)	
Storage Temperature	$-10\sim 60^\circ\text{C}$	
Dimension	$-30\sim 70^\circ\text{C}$	
Weight	38 \times 35 \times 12mm(L \times W \times H)	
Lifespan	<30g	
	$\geq 5\text{years}$	

Pin Order:

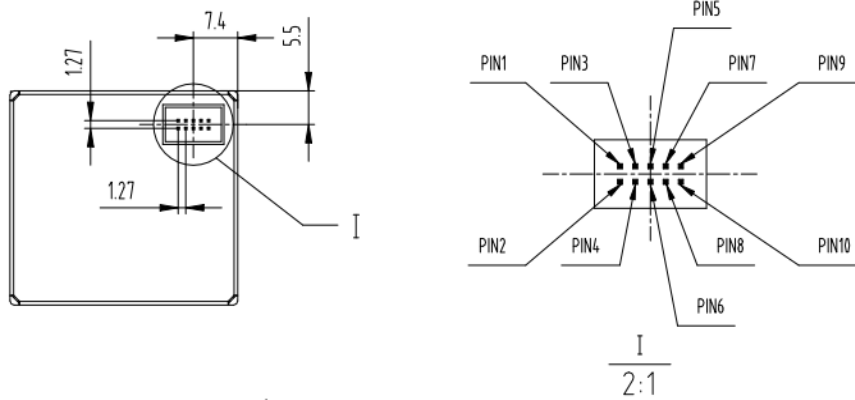

Figure1-Pin Order

Pin Definition:

Table2-Pin Definitions

No.	Name	Description
PIN1	TXD	TTL@3.3V
PIN2	SET	Setting Terminal (TTL @3.3V, high level or floating is normal working state, low level is sleep state)
PIN3	RXD	TTL@3.3V
PIN4	Reserved	NC
PIN5	Reserved	NC
PIN6	PWM Output	TTL@3.3V
PIN7、PIN8	GND	GND
PIN9、PIN10	VDD	Power input +5V

Terminal Description:

Sensor terminal and matching terminal description:

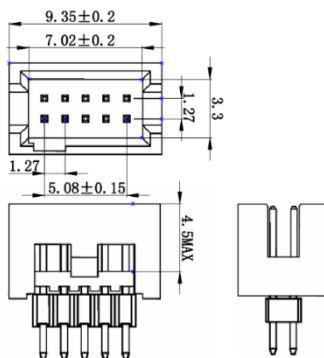

Figure 2-Terminal Model (PH=2x5x1.27mm)

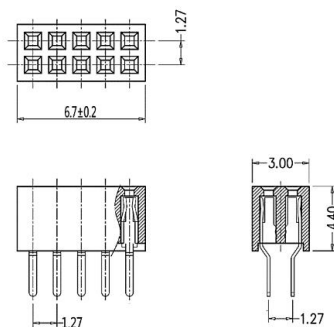

Figure 2-1 Mating terminals(for reference only)

Note: The matching terminals in Figure 2-1 are for reference only. When using the SMD mating terminal to connect the sensor, ensure a safe distance between the sensor housing and the terminal pins to prevent short-circuit and other faults.

Principle Description:

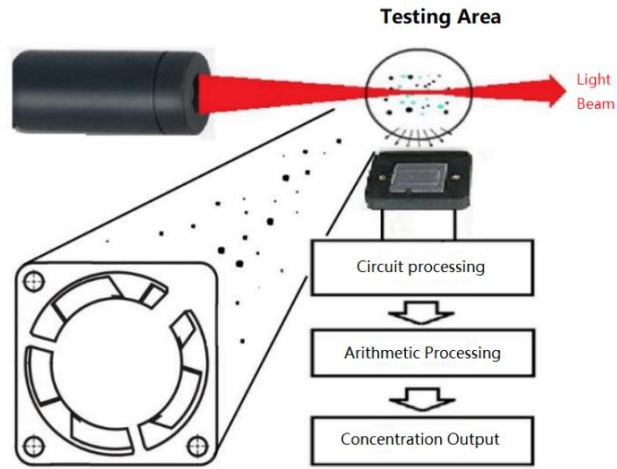
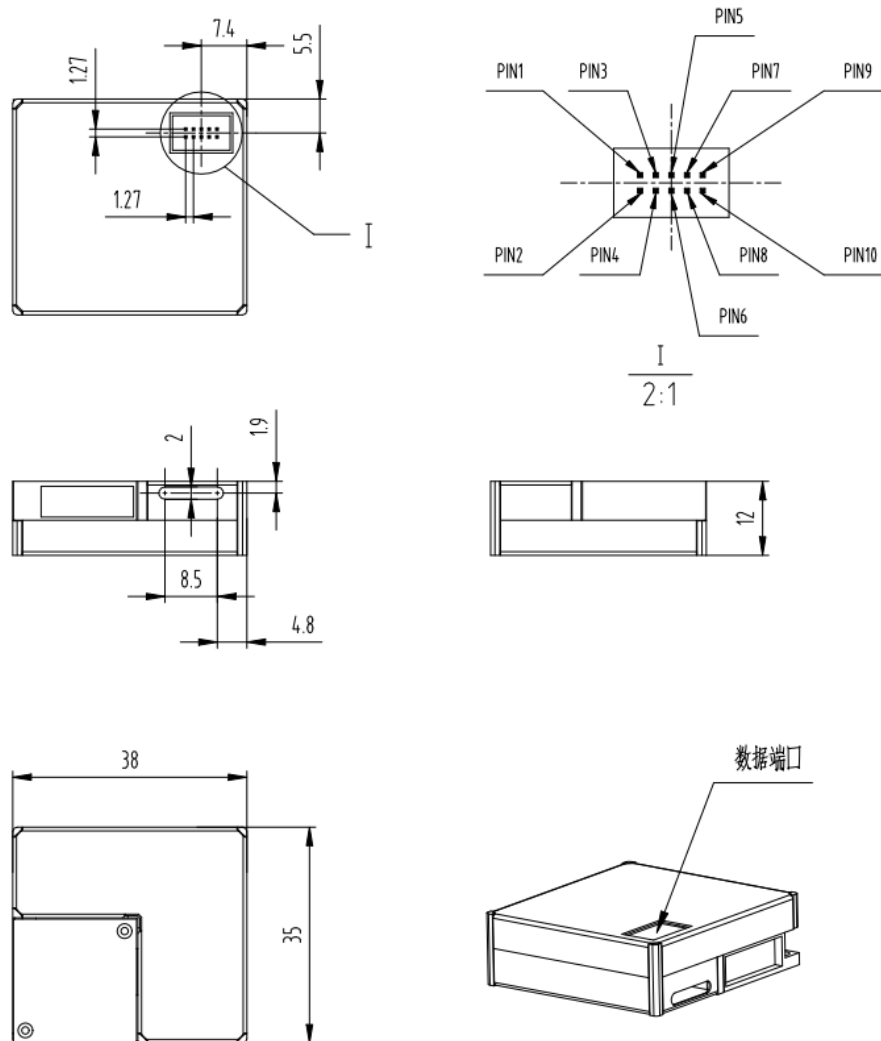

Figure 3-Principle Description

Sensor Construction:



Note: Dimensional tolerance: $\pm 0.5\text{mm}$

Figure 4-Dimension

Installation Methods:

The dust collection hole is the air inlet inside the sensor, which needs to keep good contact with the external air; the fan is installed at the air outlet inside the sensor. When the sensor is installed and working, must avoid strong airflow interference around the sensor; if it cannot be avoided, try to keep the external airflow direction perpendicular to the internal airflow direction of the sensor.

When designing the detection cavity of the whole machine, the effective area of the sampling port of the sensor should be fully considered to ensure the smoothness of the sampling gas path as much as possible. Small sampling area and large air resistance will seriously affect the accuracy of sensor data.

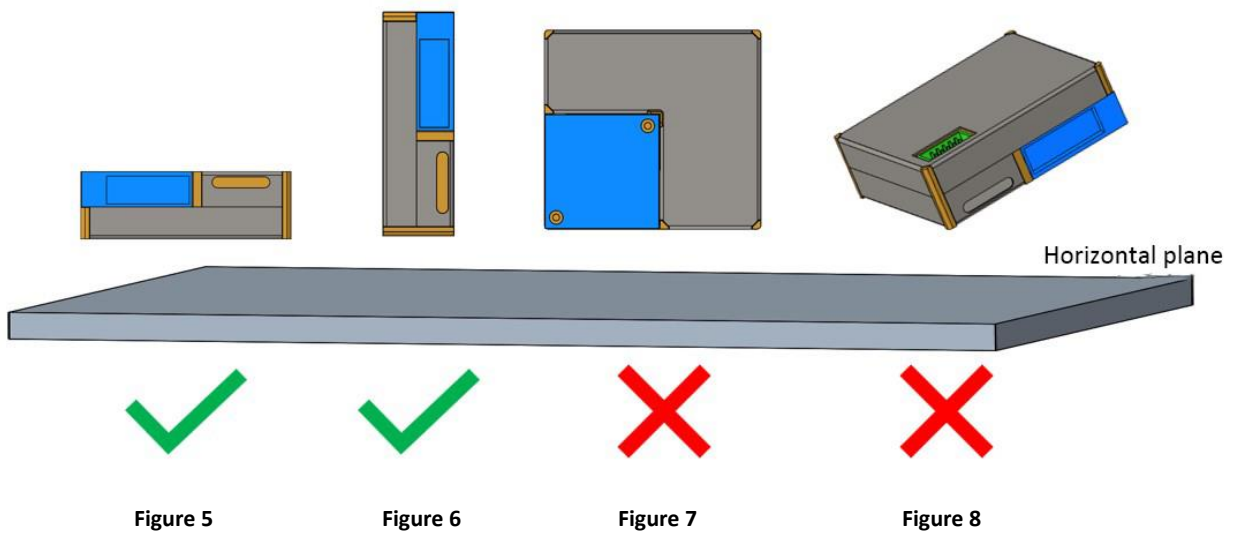

Arrows indicate airflow perpendicular to the sensor surface

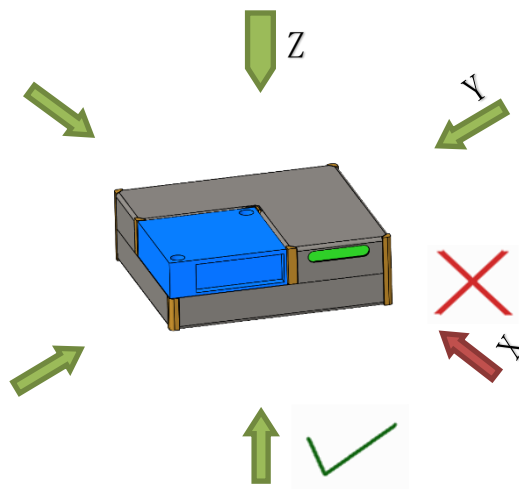

Figure 9

PM2.5 Typical Output Characteristics:

ZH10 conformance testing against TSI8530

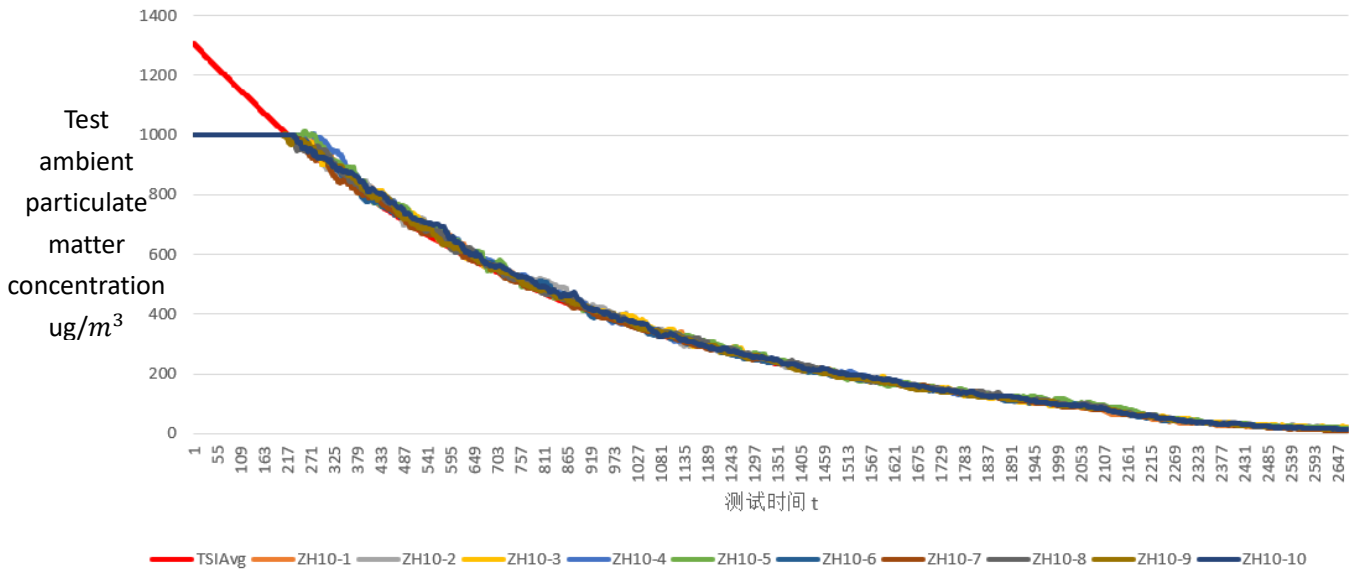

Figure 10

Note:

The picture shows the data comparison between the conventional ZH10 laser particle sensor and TSI8530 in the test environment.

Abscissa: Testing time related parameters, Unit: s;

Ordinate: The concentration of particles in the test environment (with TSI8530 data as reference, unit: $\mu\text{g}/\text{m}^3$).

Notes for VOC sensors:**1. Preheating time**

Sensor's resistance may drift reversibly after long-term storage without power. It need to preheat the sensor to reach inside chemical equilibrium. Preheating voltage is same with heating voltage VH. The suggested preheating time as follow:

Storage Time	Suggested aging time
Less than one month	No less than 24 hours
1-6 months	No less than 48 hours
More than six months	No less than 72 hours

2. Following conditions must be prohibited**2.1 Exposed to organic silicon steam**

Sensing material will lose sensitivity and never recover if the sensor absorbs organic silicon steam. Sensors must be avoid exposing to silicon bond, fixture, silicon latex, putty or plastic contain silicon environment.

2.2 High Corrosive gas

If the sensors are exposed to high concentration corrosive gas (such as H₂S, SO₂, Cl₂, HCL etc.), it will not only result in corrosion of sensors structure, also it causes sincere sensitivity attenuation.

2.3 Alkali, Alkali metals salt, halogen pollution

The sensors performance will be changed badly if sensors be sprayed polluted by alkali metals salt especially brine, or be exposed to halogen such as fluorine.

2.4 Touch water

Sensitivity of the sensors will be reduced when spattered or dipped in water.

2.5 Freezing

Do avoid icing on sensor's surface, otherwise sensing material will be broken and lost sensitivity.

3. Following conditions should be avoided**3.1 Water Condensation**

Indoor conditions, slight water condensation will influence sensors' performance lightly. However, if water condensation on sensors surface and keep a certain period, sensors' sensitive will be decreased.

3.2 Used in high gas concentration

No matter the sensor is electrified or not, if it is placed in high gas concentration for long time, sensors characteristic will be affected. If lighter gas sprays the sensor, it will cause extremely damage.

3.3 Long time exposed to extreme environment

No matter the sensors electrified or not, if exposed to adverse environment for long time, such as high humidity, high temperature, or high pollution etc., it will influence the sensors' performance badly.

3.4 Vibration

Continual vibration will result in sensors down-lead response then break. In transportation or assembling line, pneumatic screwdriver/ultrasonic welding machine can lead this vibration.

3.5 Concussion

If sensors meet strong concussion, it may lead its lead wire disconnected.

Notes for Laser PM sensor:

1. It is forbidden to remove the shield cover of the sensor and the internal fixing screw of the sensor, because the shield cover of the sensor is connected with the internal power supply of the sensor through the internal spring. If the shield cover of the sensor is removed, the anti-interference ability of the sensor will be poor, the output value of the sensor will change, and the performance of the sensor will be poor. In addition, and please pay attention to the metal shield of the sensor, avoid contact with other external circuits or conductive parts, so as to reduce the impact of external interference on the sensor.
2. Excessive impact or vibration will affect the accuracy and life of the sensor detection value, so the sensor should avoid falling or vibration when installing and using.
3. This sensor is suitable for the detection of dust particles in the ordinary indoor environment. The actual working environment should try to avoid oil & smoke environment, too large dust particles, high humidity environment, such as: kitchen, bathroom, smoking room, outdoor environment, etc. If it is used in such environments, corresponding protective measures shall be added to the user's equipment to prevent viscous particles or large particles from entering the interior of the sensor and forming accumulation in the interior of the sensor which will affect the performance of the sensor. (for example, in the working environment with floccules or fibers, the corresponding coarse filter net should be added ahead the air inlet of the sensor to avoid floccules or large sundries from entering the sensor and blocking the light path of the sensor, thus affecting the detection accuracy of the sensor.)
4. The fan is the air outlet, and the dust collection hole is the air inlet. During the using of the sensor, the sensor should not be directly placed inside the air duct of the purifier. If it cannot be avoided, an independent space structure should be set up for the installation position of the sensor. The air flow direction is as shown in 'Installation Method'. The sensor should not be impacted by the air flow in the direction of the red arrow. There should be no obstructions within 2cm around the outlet of the fan. In this independent space, it should be avoided that the air flow from the outlet directly flows back to the inlet, which will affect the accuracy of detection.
5. Under normal working condition of normal temperature & pressure, the key component of the sensor-laser, can work continuously for more than 10000 hours, and the life of the sensor can be greatly prolonged by setting the sensor's sleep mode and interval working time. The maximum cumulative life of the sensor can be more than 3 years. Please refer to the user interface instructions for detailed operation methods, or you can contact our technical service staff by telephone or email.
6. The sensor data mentioned in this manual is about to ensure the consistency of the sensors we produced, the comparison standard will not refer to any third-party testing instruments or data. If the user wants the final detection results to be consistent with the third-party testing instrument, the user can do data fitting correction according to the actual detection results.

Packing:

- 1.Put the sensor into the Pearl Foam Tray as shown in the picture below.
 - 2.Put the whole plate of sensors in Small Box one by one (Figure 11), then puts a foam plate at the top. Each Small Box can hold 20 sensors.
 - 3.Select the appropriate carton according to the quantity of the order:
Carton F: 355 x 310 x 285mm, can hold 160 sensors. (Figure 12)
Carton D: 630 x 280 x 405mm, can hold 480 sensors. (Figure 13)
- Note: Please pay attention to water proof of the carton during transportation.

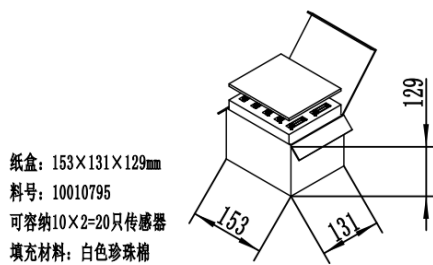

Figure 11-inner box

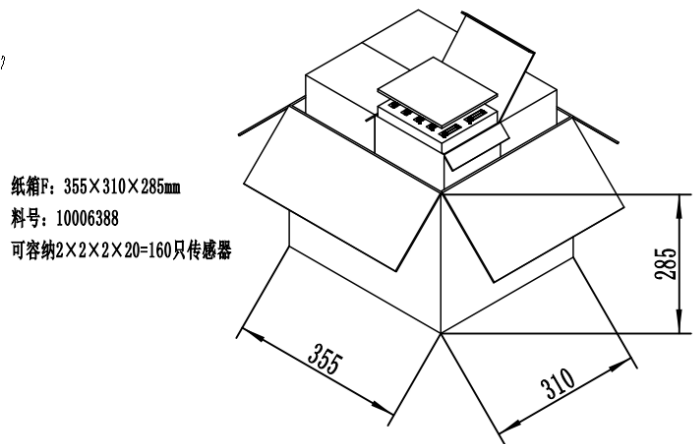

Figure 12-Carton F

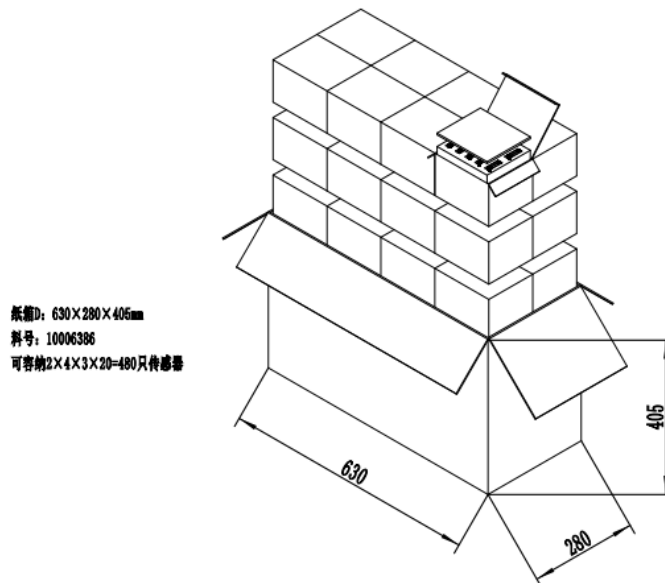

Figure 13-Carton D

Communication protocols:

Table3-Serial port configuration

Name	Description
Baud rate	9600
Date byte	8 bytes
Stop byte	1 byte
Check byte	no

The command to read the measurement results is as follows:

Sent: FF 01 35 00 00 00 00 00 CA

Received: FF 01 35 DF1-DF2 DF3-DF4 DF5-DF6 DF7-DF8 DF9-DF10 DF11-DF12 DF13-DF14 DF15-DF16 DF17-DF18
[CS]

VOC Reserved PM1.0 PM2.5 PM10 TEMP HUMI

Response description:

- 1、 DF1-DF2 VOC level = $DF1 * 256^1 + DF2$, (Output value multiplied by 10), unit: ppb
- 2、 DF3-DF4 reserved
- 3、 DF5-DF6 $PM1.0 = DF5 * 256^1 + DF6$, unit: ug/m3
- 4、 DF7-DF8 $PM2.5 = DF7 * 256^1 + DF8$, unit: ug/m3
- 5、 DF9-DF10 $PM10 = DF9 * 256^1 + DF10$, unit: ug/m3
- 6、 DF11-DF12 Temperature = $DF11 * 256^1 + DF12$, unit: °C (actual temperature = $((DF11 * 256^1 + DF12) - 500) / 10$)
- 7、 DF13-DF14 Humidity = $DF13 * 256^1 + DF14$, unit:% (actual humidity = $(DF13 * 256^1 + DF14 / 10)$)
- 8、 DF15-DF16 Reserved
- 9、 DF17-DF18 Reserved
- 10、 CS $CS = (\sim (Data[1]+Data[2]+...+Data[20]) + 1)$